

dyson

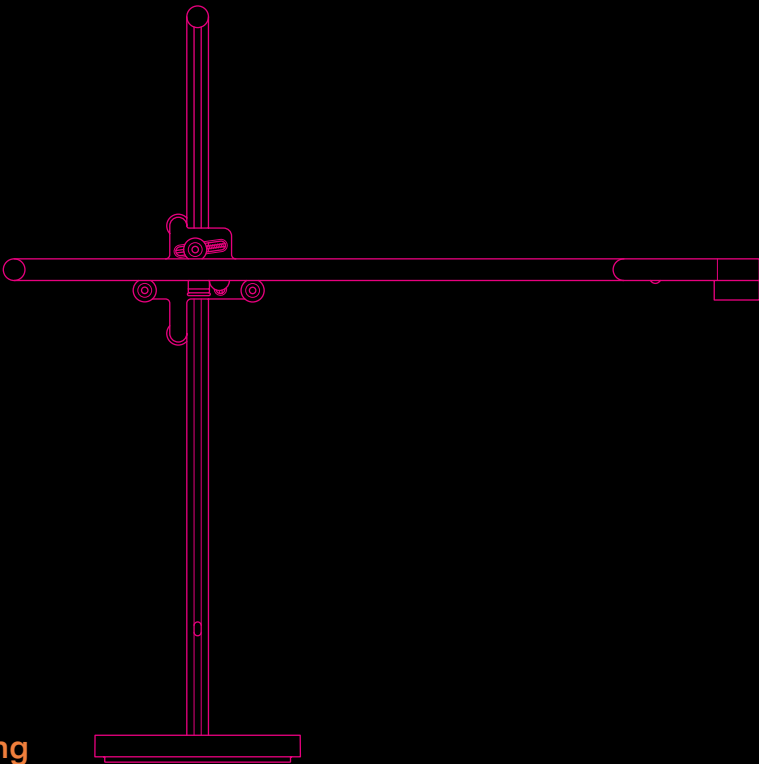

Suspended
and task lighting

Lightcycle™ task lighting

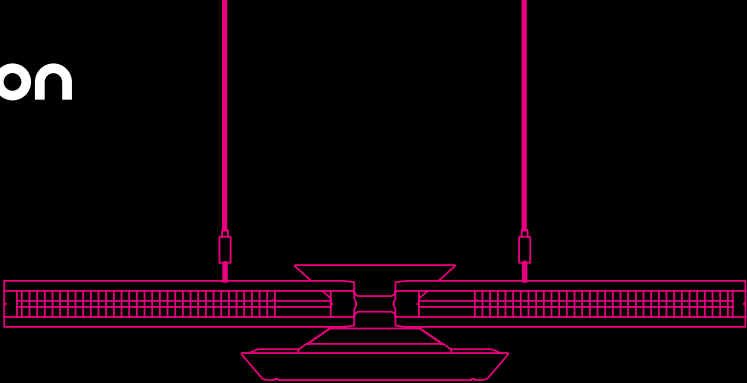

“LED luminaires can overheat
and quickly deteriorate.
I wanted to develop
one that wouldn't.”

Jake Dyson
Chief Lighting Engineer



The problem with LEDs

Without proper cooling, LEDs can quickly overheat. When this happens, their phosphor coating can burn – causing color-shift, fading and an overall deterioration in light quality.

Intelligently tracks local daylight. With Heat Pipe technology to protect light quality for 60 years.¹

Maintains light quality for decades¹
Heat Pipe technology keeps LEDs
cool, protecting light quality.

Tracks local daylight

Provides the right type of light for the time of
day. Uses a unique time, date and GPS-driven
algorithm. Software validation supported by
data selected from atmospheric measurements
of natural light.



Heat Pipe technology

To prevent overheating, which can
cause deterioration and color-shift,
a vacuum-sealed copper tube draws
heat away from LEDs.

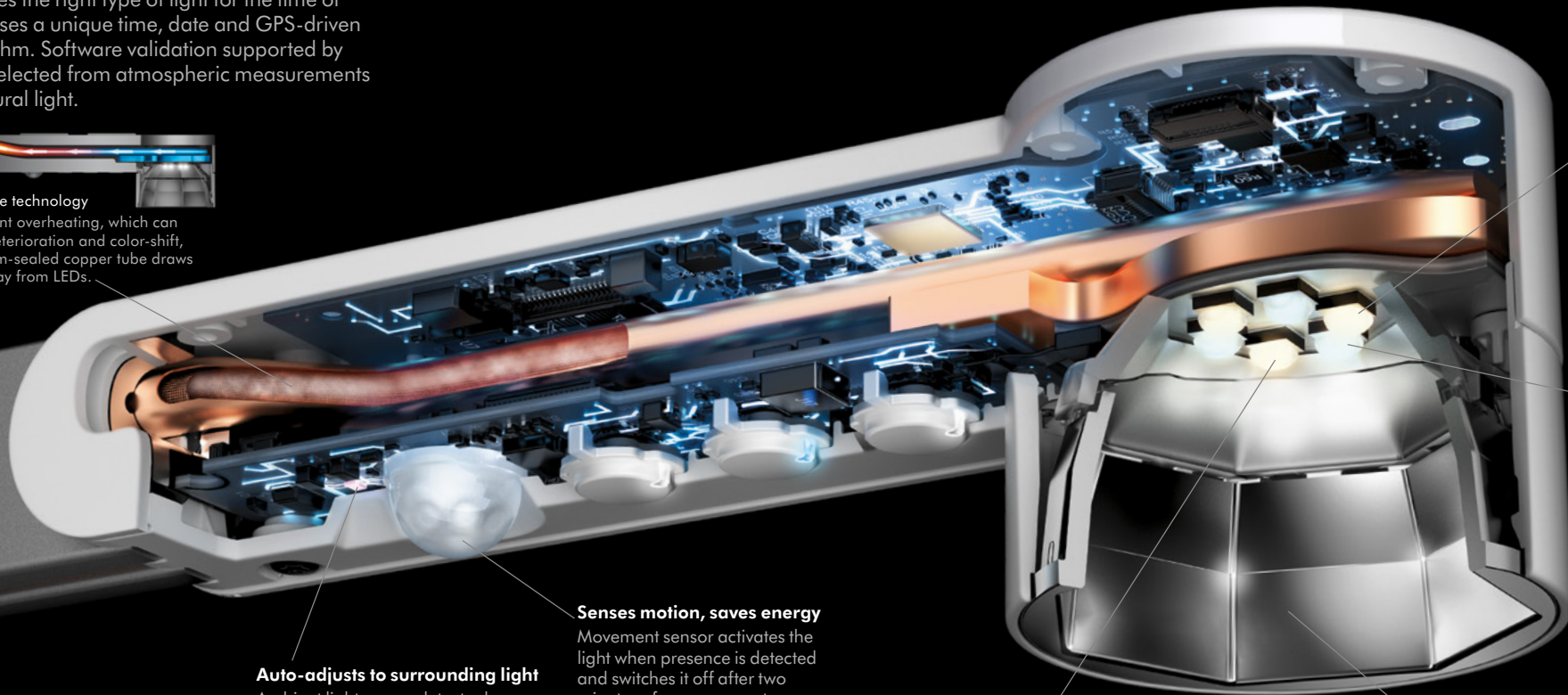

Provides high CRI and uniformity

Color rendering index
of 90 or above, and
0.7 uniformity.

Delivers powerful, high quality light

Designed to help
reduce eye strain
with over 1000lx
and low optical flicker
(at less than 1%).³

Senses motion, saves energy

Movement sensor activates the
light when presence is detected
and switches it off after two
minutes of no movement.



Auto-adjusts to surrounding light

Ambient light sensor detects changes
in background light, keeping your
workspace at a constant brightness.

● ○
AUTO

Connects for personalization

Intelligently adjusts for your age,
task, location and daily routine.
Controlled by the Dyson Link app.²



Dynamically color tunes

Simulates a wide range of
daylight color temperatures.

2700 kelvin 6500 kelvin

Protects from glare

Split-level reflector shields
eyes from the light source.

¹LED-life calculation is based on L70 measurement according to IEC 62717, with an estimation of 8 hours usage per day. Real-life results may vary.
²Requires device to run app, Wi-Fi or mobile data, Bluetooth 4.0 support, and iOS version 10 or Android version 5 (or above). Standard data and messaging
rates may apply. ³Tested at full brightness according to IEEE 1789 - 2015 - Recommended Practices for Modulating Current in High-Brightness LEDs for
Mitigating Health Risks to Viewers.

The Bluetooth® word mark and logos are registered trade marks owned by the Bluetooth SIG, Inc. and any use of such marks by Dyson is under license.

Dyson daylight algorithm Intelligently calculates daylight properties

Daylight is complex. It changes throughout the day and year, varying in every location. Dyson engineers developed a unique time, date and GPS-driven algorithm to calculate the changing color temperatures and brightness of daylight, anywhere in the world. To assist accuracy, our software validation was supported by data selected from atmospheric measurements.

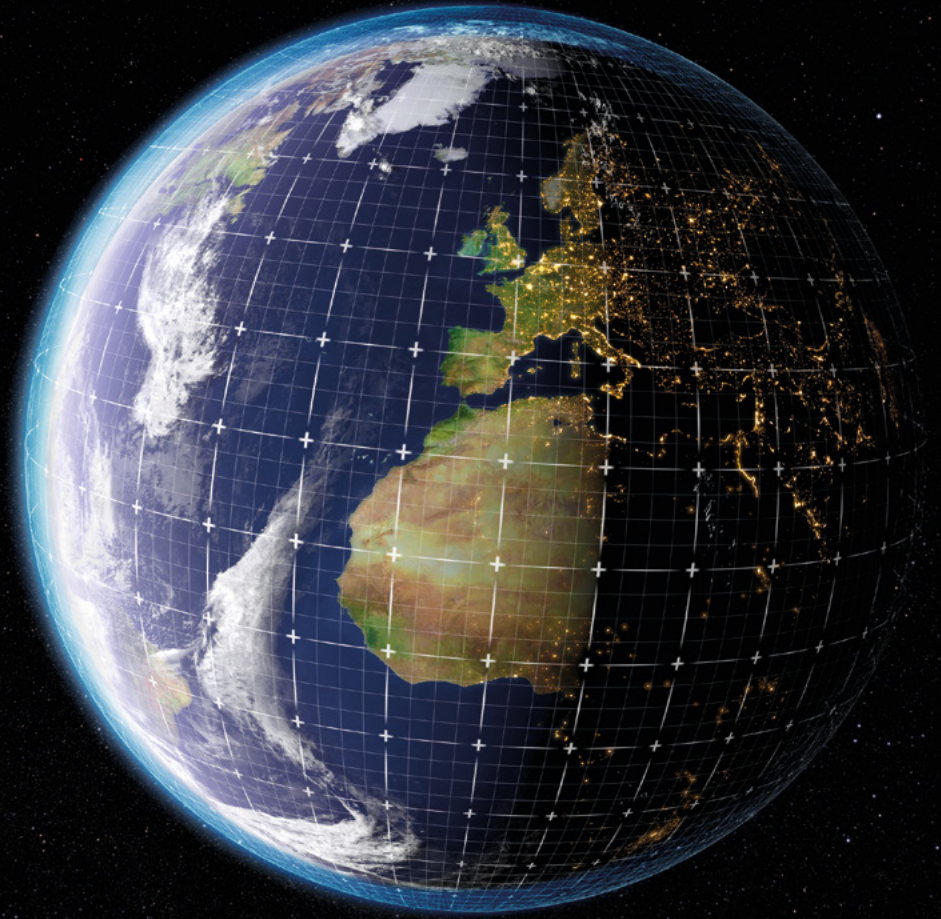

DAYLIGHT TRACKING

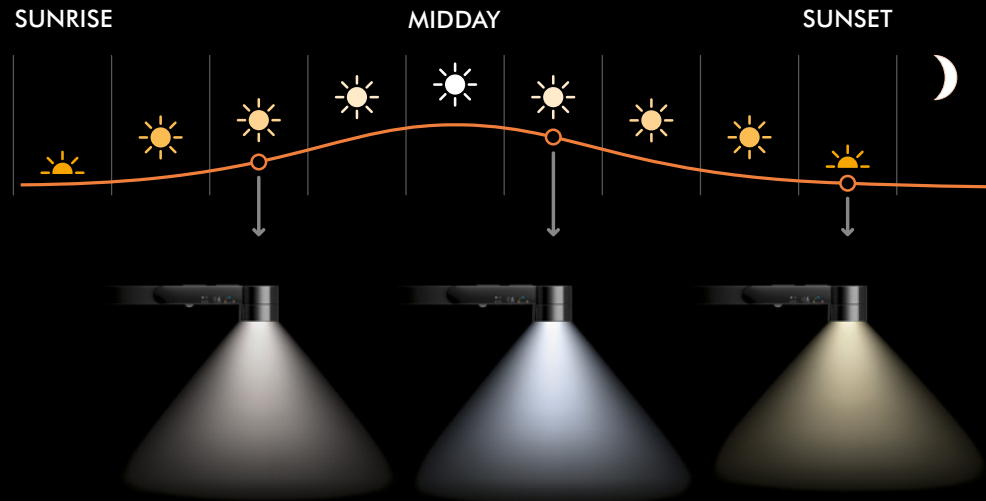

The right light, at your fingertips

Connects to the Dyson Link app²

Using input from your smartphone, the Lightcycle™ task light intelligently adapts to your age, task and location, and provides more personalized light settings to suit your daily routine.

Local daylight mode

Uses data from the app's algorithm to adjust color temperature and brightness with daylight in your location. So it provides the right light for the time of day.

Study mode

Surpasses recommended light levels for office work, while tracking the color temperature of your local daylight (from 3600-5200K). So you work under the right type of light for the time of day.

Precision mode

Helps reduce eye strain by emitting a pool of high-intensity light with a cooler (4600K) color temperature. The light achieves over 90 CRI, displaying colors very close to daylight.

Relax mode

Provides a warm, relaxing color temperature (2900K) with low intensity which is still bright enough for reading.

Boost mode

For tasks that require extra focus, Boost mode delivers an extra 200lx and 2000K for bursts of 20 minutes.

Age adjust

When a user inputs their age into the Dyson Link app², it automatically calculates and delivers the recommended brightness (applies only to Study and Relax modes).

²Requires device to run app, Wi-Fi or mobile data, Bluetooth 4.0 support, and iOS version 10 or Android version 5 (or above). Standard data and messaging rates may apply.



dyson lightcycle

Intelligently tracks local daylight.
With Heat Pipe technology to protect light quality for 60 years.¹

LEDs stay bright for up to 181,000 hrs, cooled by Heat Pipe technology.¹

Tracks local daylight – dynamic color tuning provides the right type of light for the time of day (2700-6500K).

Designed to reduce eye strain with powerful light (over 1000lx). Surpasses recommended levels for office work.

Low optical flicker (at less than 1%)³ – driver engineered to deliver a smooth current waveform.

Intelligently adjusts for your age, task and daily routine. Controlled by the Dyson Link app.²

3 task modes: Study, Precision and Relax. (Plus Boost mode for 20 mins of higher-intensity light).

High CRI (90 or above), high uniformity (0.7) and high shadow quality.

Auto-corrects to changes in background light using an ambient light sensor.

Senses motion, saves energy – PIR sensor switches light on when you're near, and off when you're away for two minutes.

Light precisely where it's needed with 3 Axis Glide™ motion.

Integrated USB-C charger to keep devices powered up.

5 year warranty – parts and labor.

Colorways – White/Silver, Black/Black.



dyson csys

Precise, powerful illumination.
With Heat Pipe technology to protect light quality for 60 years.¹

LEDs stay bright for up to 181,000 hrs, cooled by Heat Pipe technology.¹

Designed to reduce eye strain with powerful light (over 1000lx) and glare protection – exceeds industry standards for office work.

Low optical flicker (at less than 1%)³ – driver engineered to deliver a smooth current waveform.

High CRI (90 or above), high uniformity (0.8) and high shadow quality from the COB LED and Bubble Optic lens.

Light precisely where it's needed with 3 Axis Glide™ motion.

Touch-sensitive continuous dimming.

5 year warranty – parts and labor.

Colorways – White/Silver, Black/Black.



¹LED-life calculation is based on L70 measurement according to IEC 62717, with an estimation of 8 hours usage per day. Real-life results may vary.
²Requires device to run app, Wi-Fi or mobile data, Bluetooth 4.0 support, and iOS version 10 or Android version 5 (or above). Standard data and messaging rates may apply.
³Tested at full brightness according to IEEE 1789 - 2015 - Recommended Practices for Modulating Current in High-Brightness LEDs for Mitigating Health Risks to Viewers.

The Bluetooth® word mark and logos are registered trademarks owned by the Bluetooth SIG, Inc. and any use of such marks by Dyson is under license.



Cu-Beam™ suspended lighting

“Creating lighting schemes to suit changing needs across different spaces can require multiple fixture types. Our aim was to design one light for every need, and any space.”

Jake Dyson
Chief Lighting Engineer

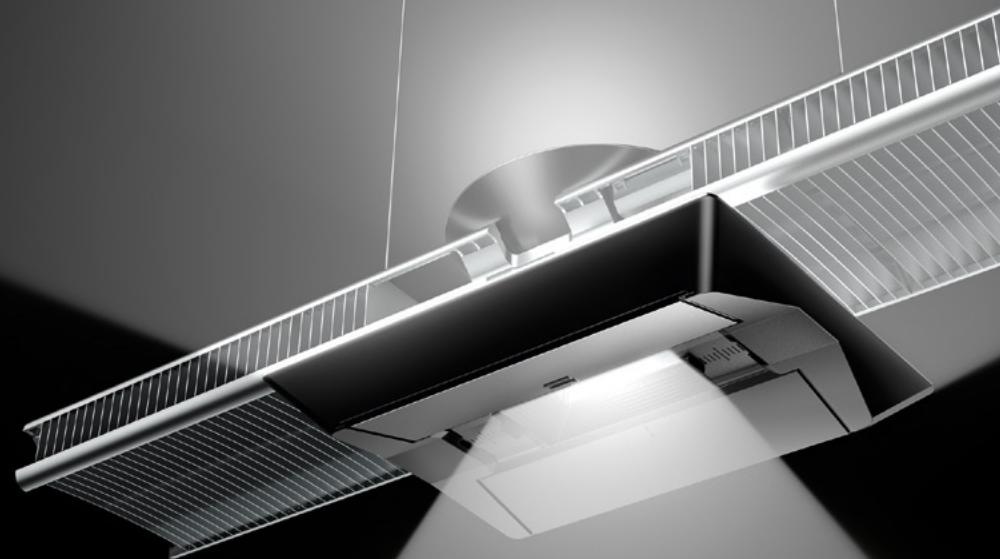

Combined up and down-light with full flexible control

By combining two high-performance LEDs, it provides both powerful up and down-lighting from one fixture. The up-light casts a wide pool of indirect light on the ceiling for illuminating wider spaces and the down-light creates focused, adjustable task lighting for working.

With Heat Pipe technology to cool its LEDs, the Cu-Beam Duo suspended light maintains LED brightness for up to 180,000 hours.⁴

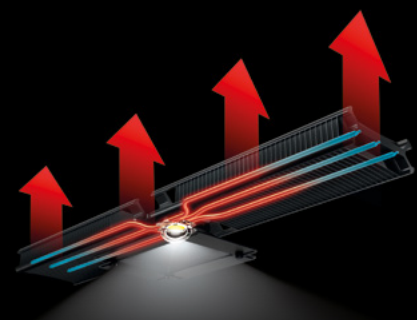

Heat Pipe technology. Cools LEDs to protect light quality.

A vacuum-sealed copper tube, connected to the LED junction by a high-efficiency thermal conductor, transfers heat away from the LEDs. Liquid inside the pipe vaporizes, then dissipates heat throughout the length of the pipe as it condenses back to liquid, returning to the heat source via capillary action.

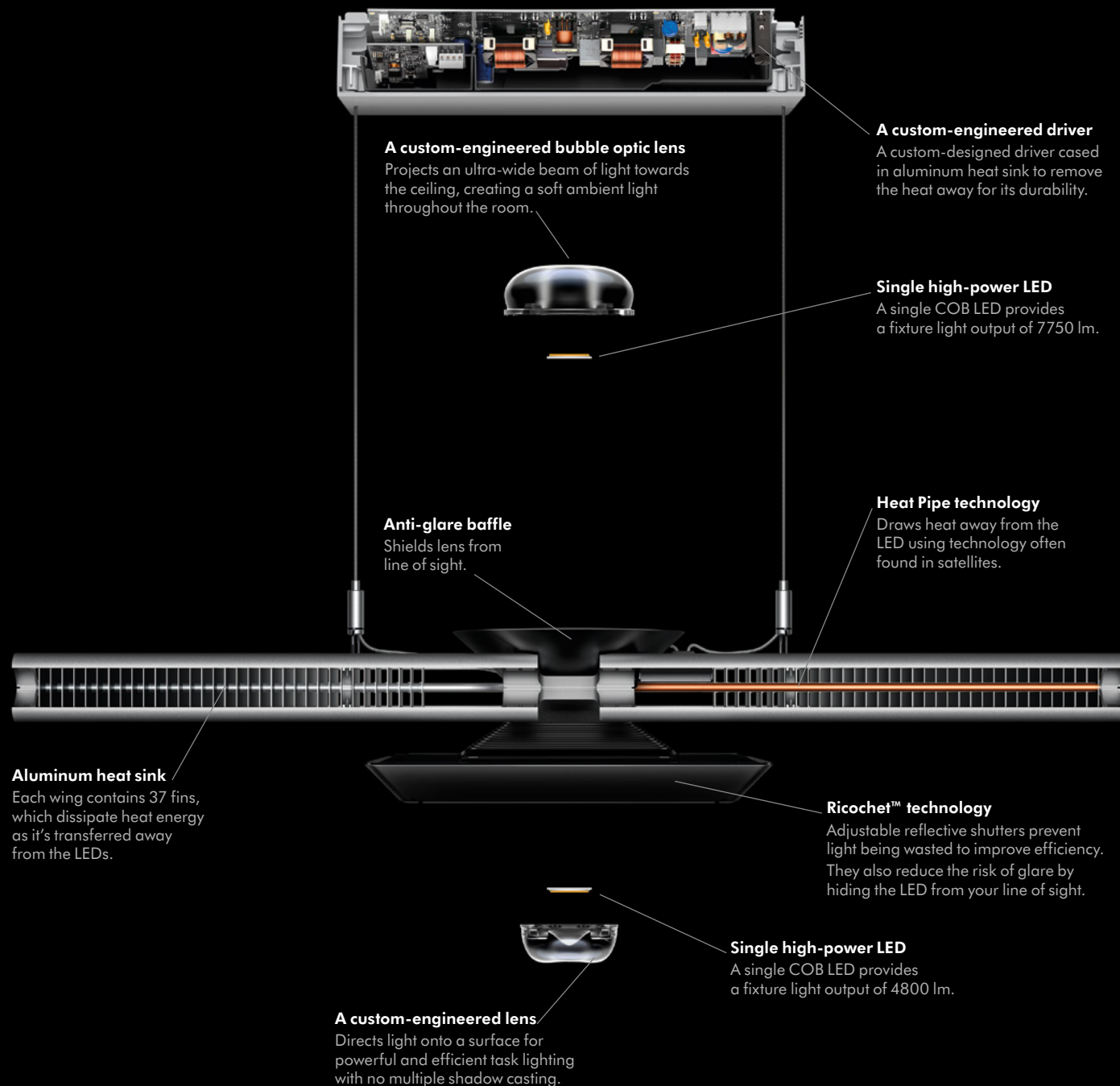

A custom-engineered bubble optic lens

Projects an ultra-wide beam of light towards the ceiling, creating a soft ambient light throughout the room.

A custom-engineered driver

A custom-designed driver cased in aluminum heat sink to remove the heat away for its durability.

Single high-power LED

A single COB LED provides a fixture light output of 7750 lm.

Anti-glare baffle

Shields lens from line of sight.

Heat Pipe technology

Draws heat away from the LED using technology often found in satellites.

Aluminum heat sink

Each wing contains 37 fins, which dissipate heat energy as it's transferred away from the LEDs.

Ricochet™ technology

Adjustable reflective shutters prevent light being wasted to improve efficiency. They also reduce the risk of glare by hiding the LED from your line of sight.

Single high-power LED

A single COB LED provides a fixture light output of 4800 lm.

A custom-engineered lens

Directs light onto a surface for powerful and efficient task lighting with no multiple shadow casting.

⁴Calculated lifetime based on LED L70.

dyson cu beam duo

Combined up and down-light with full flexible control.

Alters to suit changing needs throughout the day.

LEDs stay bright for up to 180,000 hours⁴ due to Heat Pipe technology.

Powerful up and down-light from one product.

Custom-engineered lens and trim blades project direct light precisely where you need it.

The down-light projects up to 722lx at 4000K evenly over an area of 10.5ft x 5.3ft / 3.2m x 1.6m when mounted 4.3ft / 1.3m above the task area.⁵

The up-light projects up to 733lx at 4000K evenly over an area of 13ft / 4m wide when mounted at a 15.8in / 400 mm drop height from the ceiling.⁵

High efficacy with up to 113lm/W at 4000K.

Weighs only 7lb / 3.2 kg.

5 year warranty – parts only.

Colorways – Silver, Black, White.

dyson cu beam down

Suspended down-light with a controlled pool of powerful illumination.

Ideal for lighting task surfaces such as meeting tables and office desks.

LEDs stay bright for up to 180,000 hours⁴ due to Heat Pipe technology.

Powerful LED light (5350lm at 4000K).

Custom-engineered lens and trim blades project direct light precisely where you need it.

Projects up to 674lx at 4000K evenly over an area of 10.5ft x 5.3ft / 3.2m x 1.6m when mounted 4.3ft / 1.3m above the task area.

High efficacy at 94lm/W at 4000K.

Weighs only 6lb 6oz / 2.9 kg.

5 year warranty – parts only.

Colorways – Silver, Black, White.

dyson cu beam up

Suspended up-light with an ultra-wide distribution of powerful illumination.

Ideal for open spaces such as atriums, foyers and general office lighting.

LEDs stay bright for up to 180,000 hours⁴ due to Heat Pipe technology.

Powerful LED light 7800lm at 4000K.

Custom-engineered lens projects wide beam of ambient light precisely where you need it.

Projects up to 690lx at 4000K evenly over an area of 13ft / 4m wide when mounted at 15.8in / 400 mm drop height from the ceiling.

High efficacy with up to 92lm/W at 4000K.

Weighs only 6lb 6oz / 2.9 kg.

5 year warranty – parts only.

Colorways – Silver, Black, White.



⁴Calculated lifetime based on LED L70.

⁵Based on 50/50 split of up and down light.

Lightcycle™ task lighting Specifications

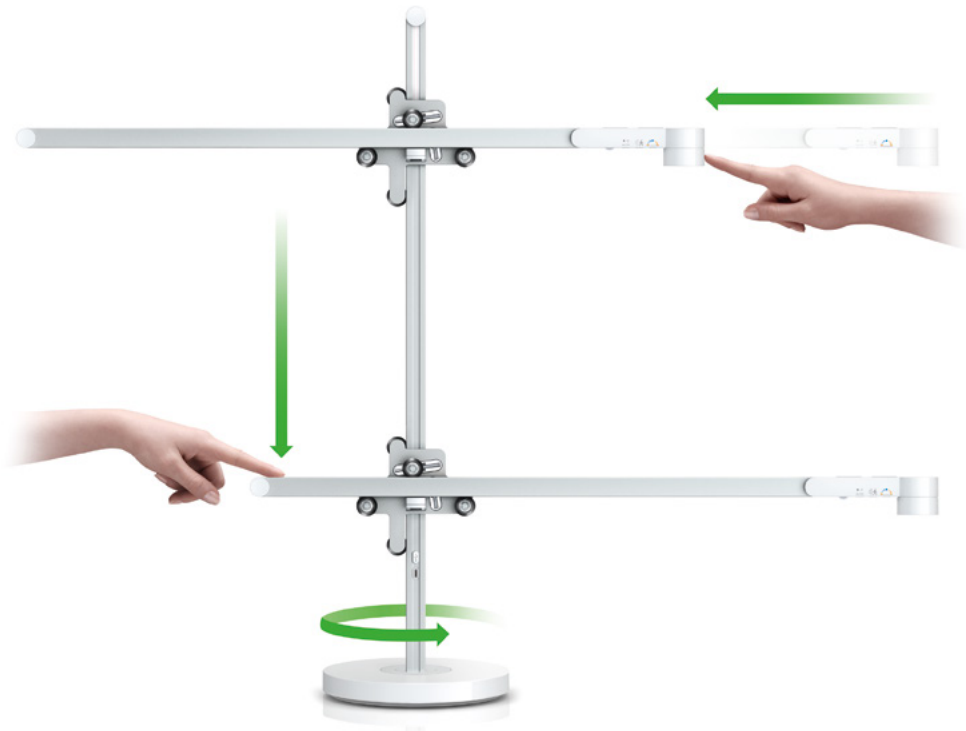

dyson lightcycle desk

Visit website for full downloadable
technical specifications.
www.dyson.com

Luminaire dimensions

H 27.7in (703 mm) W 27.6in (702 mm) D 7.5in (190 mm)

FRONT ELEVATION

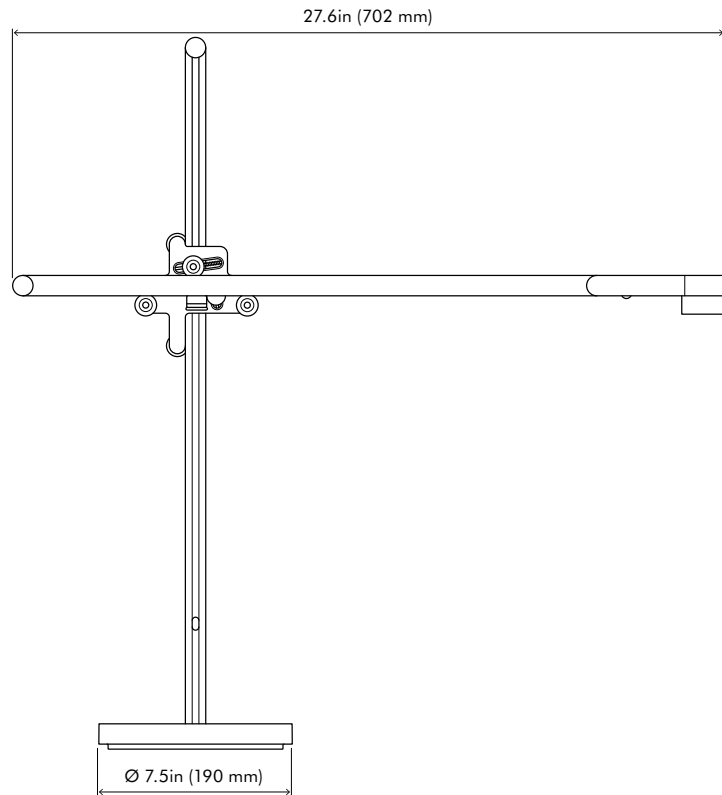

SIDE ELEVATION

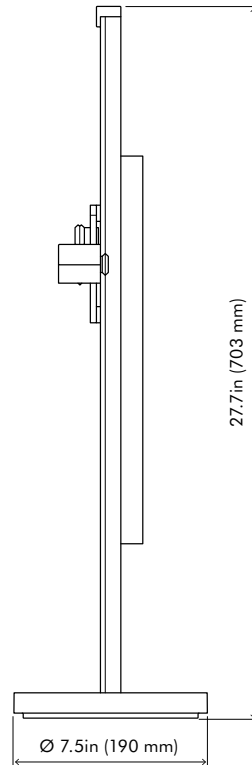

dyson csys

Visit website for full downloadable
technical specifications.
www.dyson.com

Luminaire dimensions

H 27.7in (703 mm) W 27.6in (702 mm) D 7.5in (190 mm)

FRONT ELEVATION

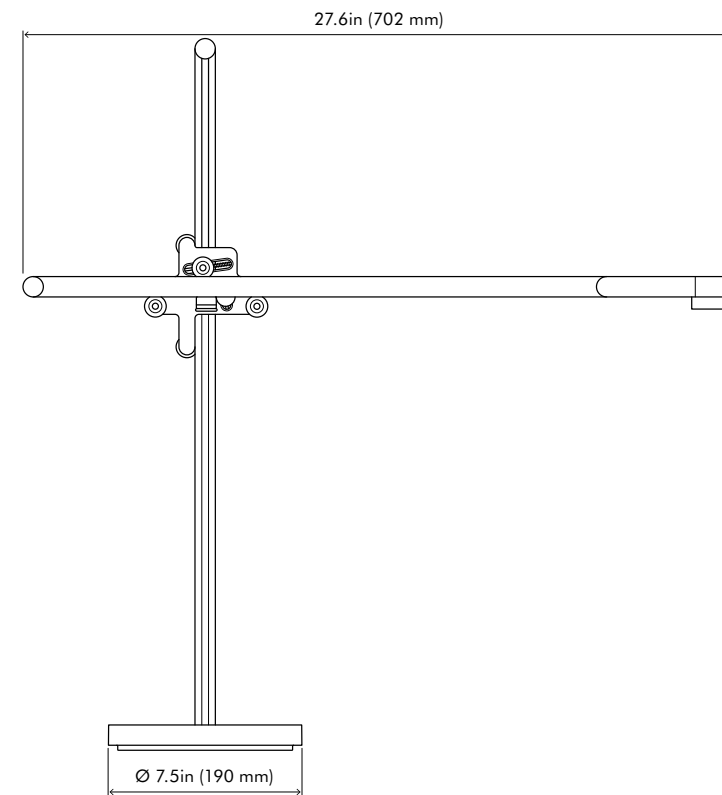

SIDE ELEVATION

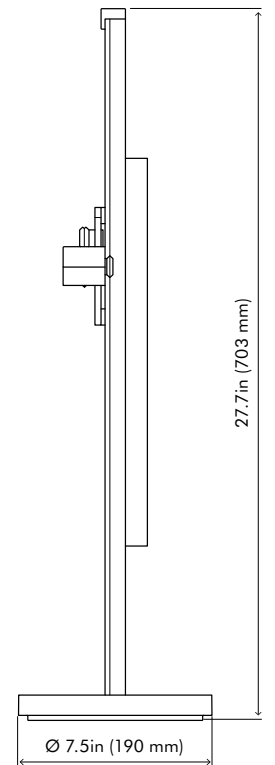

Cu-Beam™ suspended lighting Specifications

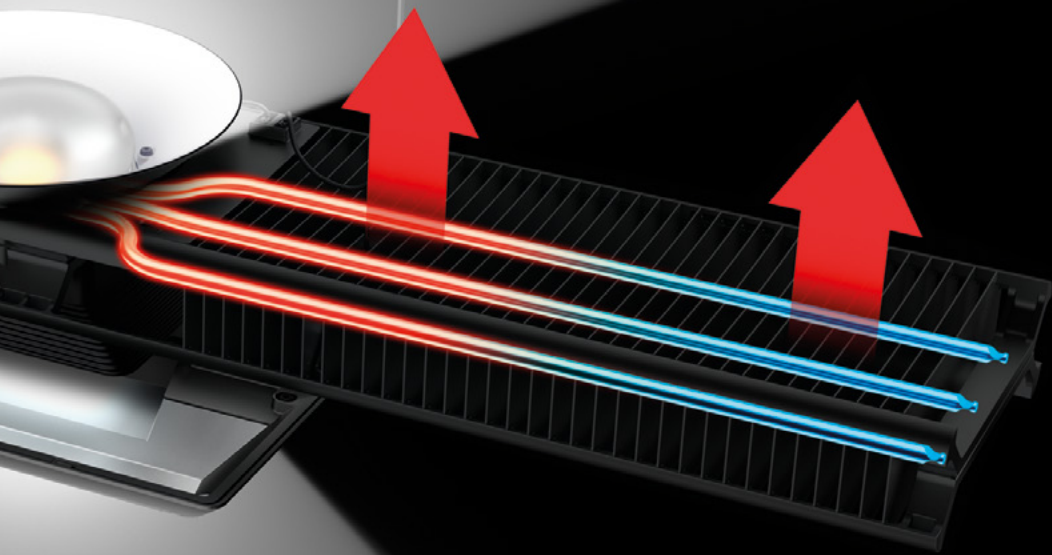

dyson cu beam duo

Visit website for full downloadable technical specifications.
www.dyson.com

Luminaire dimensions

H 3.8in (97 mm) W 28.5in (725 mm) D 8.1in (206 mm)

Driver dimensions

H 2.2in (55 mm) W 12.2in (310 mm) D 4.3in (110 mm)

Minimum clearance from ceiling

15.8in (400 mm)

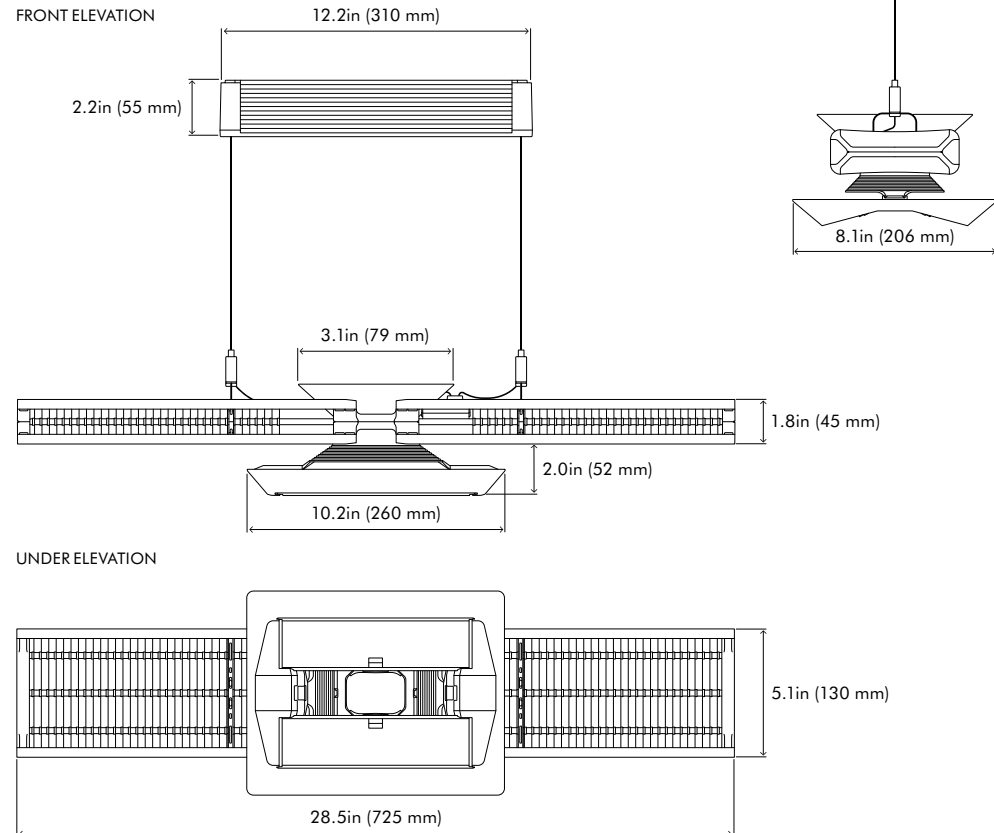

dyson cu beam down

Visit website for full downloadable technical specifications.
www.dyson.com

Luminaire dimensions

H 3.5in (89 mm) W 28.3in (720 mm) D 5.1in (130 mm)

Driver dimensions

H 2.2in (55 mm) W 12.2in (310 mm) D 4.3in (110 mm)

Minimum clearance from ceiling

15.8in (400 mm)

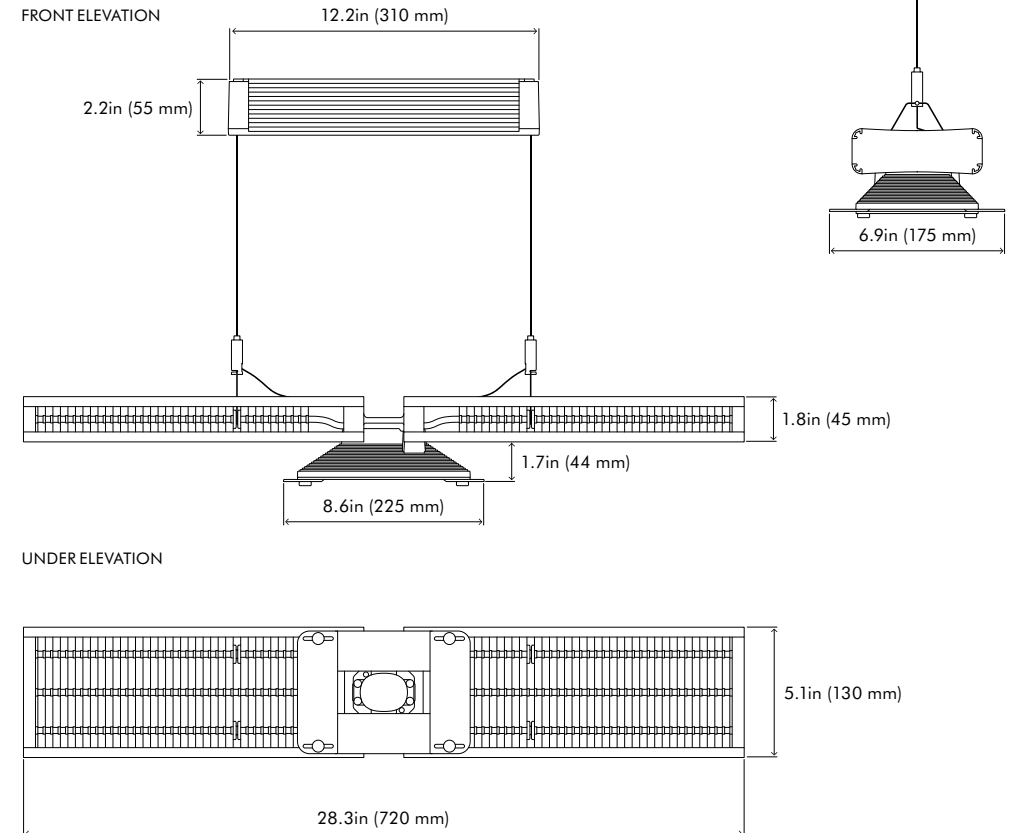

dyson cu beam up

Visit website for full downloadable
technical specifications.
www.dyson.com

Luminaire dimensions

H 2.3in (60 mm) W 28.3in (720 mm) D 5.1in (130 mm)

Driver dimensions

H 2.2in (55 mm) W 12.2in (310 mm) D 4.3in (110 mm)

Minimum clearance from ceiling

15.8in (400 mm)

FRONT ELEVATION

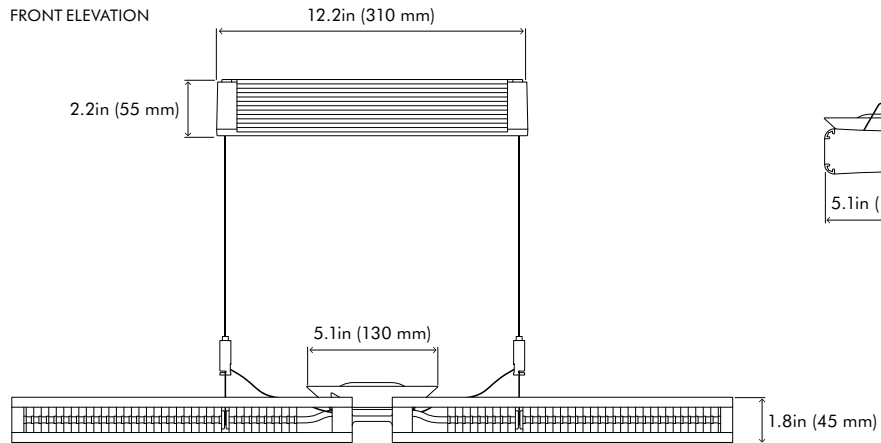

SIDE ELEVATION

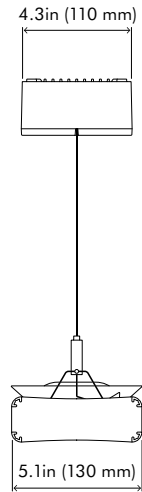

TOP ELEVATION

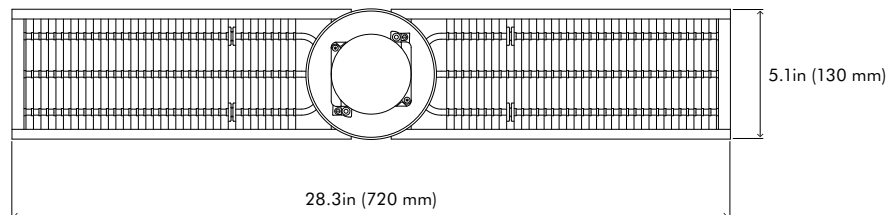

For more information
please contact:
855-720-6377
lighting@dyson.com
www.dyson.com

dyson